

Product Information Bulletin

1" GEN 2 SPM Cartridge & Valve Product Line

REV	DATE	DESCRIPTION	ORIGIN (issued by)	APPROVED
001	05-08-20	Document No.: 105-050820-001	AP	BR

**COMPANY PROPRIETARY INFORMATION**

© 2014 - 2020 Proserv Gilmore Valve, LLC and/or its affiliates (Gilmore). All rights reserved. Proserv®, Gilmore™, Gilmore & Design (Stallion) and Gilmore, a Proserv Company™ are registered trademarks or trademarks of Gilmore. This Bulletin and the information contained herein is not to be, in whole or in part, reproduced or transmitted in any form by any means without the express permission of Gilmore. **DISCLAIMER:** Whilst Gilmore has carefully reviewed the contents of this Bulletin and believes the information to be correct, Gilmore does not assume any liability in connection with any use of or reliance upon this information and gives no representation or warranty, express or implied, in respect of the information or any products described herein. This Bulletin is intended for use by persons having suitable technical expertise and skill, at their own discretion and risk. Gilmore may change the information contained herein at any time without notice.

---

**For more information:**

Call (800) 469-8786

[Gilmore@proserv.com](mailto:Gilmore@proserv.com)

Gilmore, A Proserv Company

1231 Lumpkin Road

Houston, TX 77043

## 1" GEN 2 SPM Cartridge & Valve Product Line



Gilmore announces the new 1" GEN 2 SPM product line for critical offshore and subsea applications. The 1" GEN 2 SPM has been redesigned with significant improvements over its predecessor. The 1" GEN 2 SPM fits within the same cavity & footprint as the legacy SPM, allowing direct replacement in existing Gilmore SPM manifolds. Gilmore's proprietary GEN 2 SPM cartridge technology provides an order of magnitude improvement in cycle life.

### Features and Benefits:

- Qualification exceeds API 16D requirements –
  - Two separate full flow tests at 2500 cycles each
- Proprietary bi-directional SPM cartridge performs in both Normally Closed or Normally Open applications
- Reduces interflow
- Reduces pressure spikes
- Improved valve materials:
  - 316 SS Body and Spring
  - Nitronic 50 Piston Rod
  - Nitronic 60 Seal Sleeve and Cage
  - Aluminum Bronze Bushing
  - Shouldered & Torqued Nylon Lock Nut
  - Dynamic T-Seals
  - HNBR Soft Seals with PEEK Double Back-up Rings
  - Delrin 511P Top and Bottom Seats with increased thickness
  - A286 Gr 660 Capscrews
  - Wide array of options available for body & port style, and customized manifolded assemblies
  - Patent Pending

**Figure 1. PN 29109: 1" GEN 2  
5000 psi Supply**

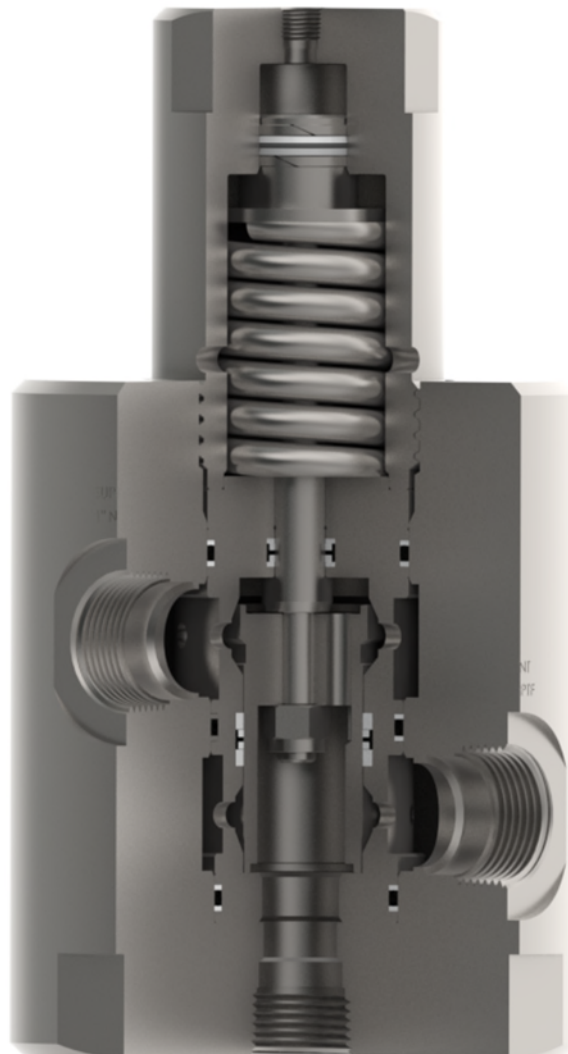

**SPM Valve, N.C., 1" NPT**

Gilmore has exceeded API 16D requirements by qualifying the new 1" GEN 2 SPM designs to multiple endurance qualification tests to 2500 cycles, at 5000 psi and 150 gpm, with 1% - 4% water glycol test fluid.

The new 1" GEN 2 SPM cartridge & valve have the identical cavity and valve footprint dimensions as the Gilmore legacy 1" SPM, allowing simple drop-in replacement to existing installations.

As a result of the new Gilmore 1" GEN 2 SPM product line, please note that new sales of the legacy 1" SPM cartridge and valve part numbers listed below will be discontinued as of May 7, 2021. The new Gilmore 1" GEN 2 SPM cartridge and valves are now available as replacements for the legacy 1" SPM cartridge and valves.

After they are discontinued, Gilmore will continue to support the discontinued legacy 1" SPM product line:

- Gilmore will continue providing repair kits and seal kits in support of discontinued legacy 1" SPM Cartridge and Valves for a minimum of 3 years. The legacy 1" SPM Cartridge and Valves listed below are field repairable.
- Gilmore Aftermarket will continue to support discontinued legacy products with factory failure analysis and repair services for a minimum of 3 years.

Please note that GEN 2 repair kits **are not** interchangeable with legacy repair kits and cannot be used in legacy SPMs. Please contact Gilmore Customer Service for any assistance needed while selecting the GEN 2 replacement valve part number.

**Table 1. New and Legacy 1 inch SPM Cartridge and Valve Part Number Cross Reference:**

Item	Legacy Description	Legacy Valve PN	Legacy Repair Kit PN*	GEN 2 Cartridge or Valve Description	GEN 2 Valve PN
1.1	MVA, 4-Way, 1" SPM, 5000 psi, 1/4 NPT Pilot Port, 1 NPT Block Ports	147581	27168-2 RK 27167-2 RK	MVA, 4-Way, 1" GEN 2 SPM, 5000 psi, 1/4 NPT Pilot Port, 1 NPT Block Ports	29123
1.2	Valve, 1" SPM, N.O., 5000 psi, 1/4 NPT Pilot Port, 1 NPT Block Ports	169129	27168-2 RK	Valve, 1" GEN 2 SPM, N.O., 5000 psi, 1/4 NPT Pilot Port, 1 NPT Block Ports	29111
1.3	Valve, 1" SPM, N.C., 5000 psi, 1/4 NPT Pilot Port, 1 NPT Block Ports	27612-1	27167-2 RK	Valve, 1" GEN 2 SPM, N.C., 5000 psi, 1/4 NPT Pilot Port, 1 NPT Block Ports	29109
1.4	Cartridge, 1" SPM, N.O., 5000 psi, 1/4 NPT Pilot Port	27167-2	27167-2 RK	Cartridge, 1" GEN 2 SPM, N.O. & N.C., 5000 psi, 1/4 NPT Pilot Port	29110
1.5	Cartridge, 1" SPM, N.C., 5000 psi, 1/4 NPT Pilot Port	27168-2	27168-2 RK	Cartridge, 1" GEN 2 SPM, N.O. & N.C., 5000 psi, 1/4 NPT Pilot Port	29110
1.6	Cartridge, 1" SPM, N.O., 5000 psi, 1/4 NPT Pilot Port, Delrin Seats	27167-3	27167-3 RK	Cartridge, 1" GEN 2 SPM, N.O. & N.C., 5000 psi, 1/4 NPT Pilot Port	29110
1.7	Cartridge, 1" SPM, N.C., 5000 psi, 1/4 NPT Pilot Port, Delrin Seats	27168-3	27168-3 RK	Cartridge, 1" GEN 2 SPM, N.O. & N.C., 5000 psi, 1/4 NPT Pilot Port	29110
1.8	Cartridge, 1" SPM, N.O., 5000 psi, 1/4 NPT Pilot Port, Delrin Seats	28478	28478 RK	Cartridge, 1" GEN 2 SPM, N.O. & N.C., 5000 psi, 1/4 NPT Pilot Port	29110
1.10	Cartridge, 1" SPM, N.C., 5000 psi, 1/4 NPT Pilot Port, Delrin Seats	28477	28477 RK	Cartridge, 1" GEN 2 SPM, N.O. & N.C., 5000 psi, 1/4 NPT Pilot Port	29110
1.11	Cartridge, 1" SPM, N.C., 5000 psi, 1/4 SAE Pilot Port	28579	28579 RK	Cartridge, 1" GEN 2 SPM, N.O. & N.C., 5000 psi, 1/4 NPT Pilot Port	29122

\*The GEN 2 valve repair kit part number will match the category part numbers with a space and (RK) at the end.

\*The GEN 2 valve seal kit part number will match the category part numbers with a space and (SK) at the end.



[www.gilmore.com](http://www.gilmore.com)

If a new Gilmore 1-1/2 inch GEN 2 SPM part number is not listed above for a specific legacy part number, please contact Gilmore Customer Service to request a quotation and creation of a new GEN 2 part number.

Please contact Gilmore Customer Service to request drawings and quotations for these SPMs at [Gilmore@proserv.com](mailto:Gilmore@proserv.com).

BC H9G

A 5F?B; .A 5F?7CA DCB9BHK #k:5GG9A 6@MK "C"  
 5G<CK B'CB'k:97CA DCB9BH8F5K B;  
 A 5F?B; .A 5F?5GG<CK B'IGB; @G9F'9H7<'CF'7CA DI H9F'  
 7CBHFC @98'8CHD99B'A 5F?B; 'A 57<B9Z"\$\* '<≠ <  
 A B'7<5F57H9FG"  
 ' " :CF'6CHCA 'G95@F9A CJ5@I G9'HC C @5H@%\$\$\$!\$\$\$"  
 (" LZ-B'7C@A B'89D=7HG'D5FHG-B'G95@?#I&- %&\$'G?"  
 )" LZ-B'7C@A B'89D=7HG'D5FHG-B'F9D5F'?#I&- %&\$'F?"  
 \* HC FE I 9'75FH-F; 9'HC " '\$\$:H@G-B'A 5B=C @B'6@7?  
 I GB; 'GD97-5@HC C @5H@%\$\$\$"  
 + 5GG9A 6@MDFC 7981 F9. .... ) \$&, &  
 G5B85F8': 5HDFC 7981 F9. .... ) \$&, '  
 9LH9B898': 5HDFC 7981 F9. .... ) \$&, ('  
 G9FJ 7'9A 5BI 5@ ..... ) %&\$\*

F9J GCBG				
F9J	9FB #97C'BI A 69F	8F5K B	7<97?98	5DDFC J 98
5	9FB '\$&', %	JOP 4/09/20	CMJ 4-13-20	AJP 4/10/20

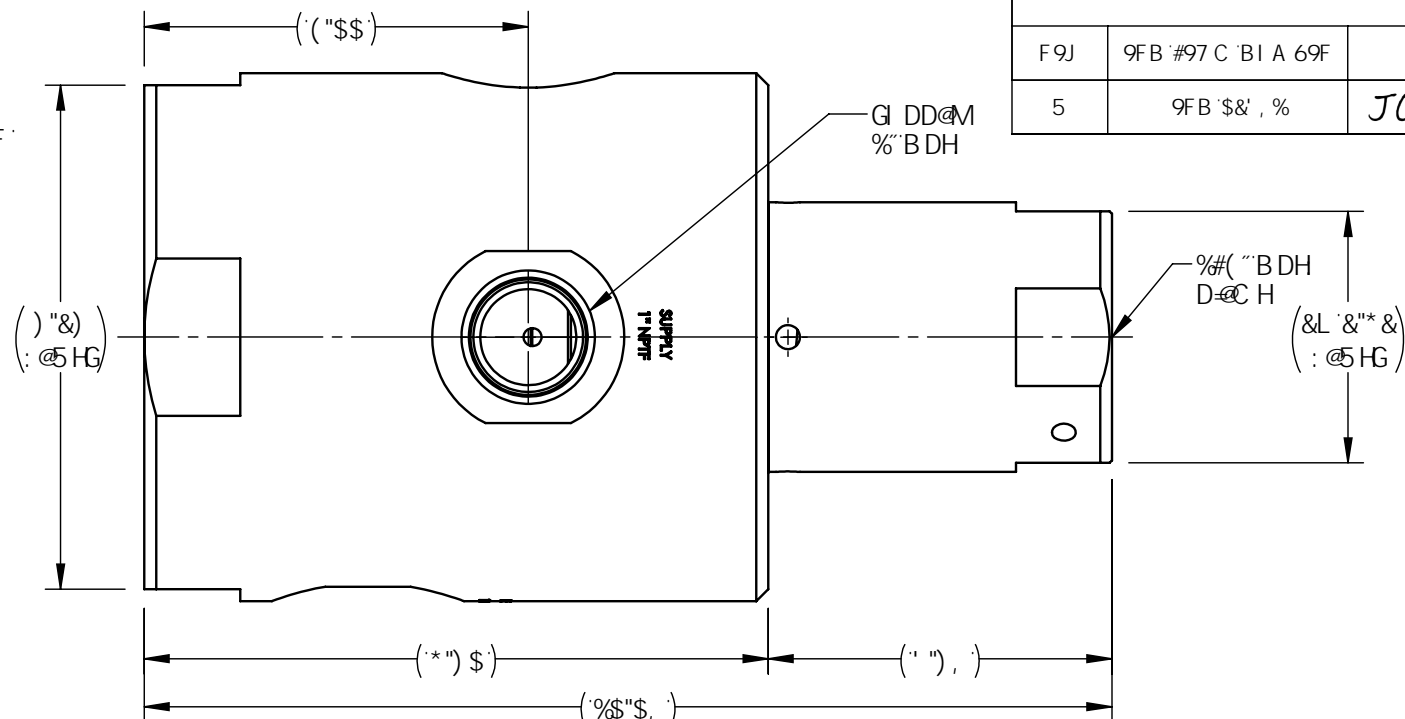

DF9GGI F985H5  
 GI DD@MA 5K D. .... ) \$\$\$ DG=  
 D@C HA 5K D. .... ) \$\$\$ DG=  
 5H) \$\$\$ DG=GI DD@MF97CA A 9B898  
 A-B-A I A 'D@C HDF9GGI F9. .... ) \$\$\$ DG=  
 5H' \$\$\$ DG=GI DD@MF97CA A 9B898  
 A-B-A I A 'D@C HDF9GGI F9. .... ) \$\$\$ DG=  
 :@K '85H5  
 7j 1;  
 A 5L: @K '75D57 #M%+); DA  
 : @-8G '%L'K 5H9F'65G98'8F-@B;  
 ..... 7CBHFC @: @-8"  
 ..... &'L'A -B9F5@C @65G98'8F-@B;  
 ..... 7CBHFC @: @-8"  
 DC FHG  
 GI DD@M ..... %'BDH  
 : I B7HC B. .... %'BDH  
 J 9BH ..... %'BDH  
 D@C H ..... %#('BDH  
 : 9B9F5@85H5  
 H9A D9F5H F9F5B; 9. .... ) &' : HC %9 \$°:  
 5DDFC L'K 9≠ <H'(' @G  
 : -9@8'G9FJ 7'956@

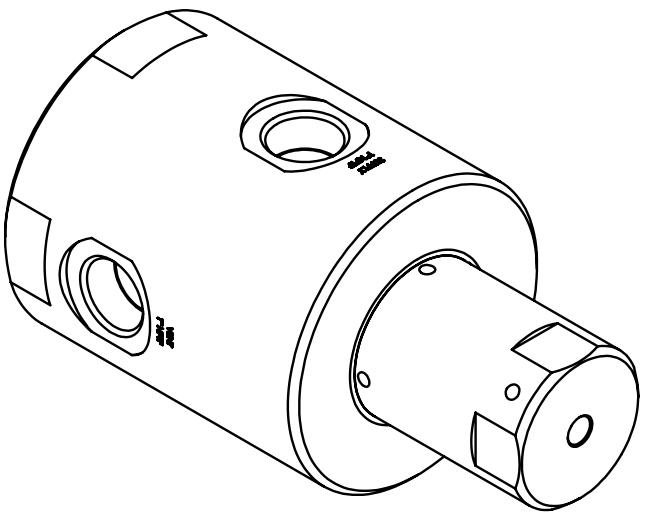
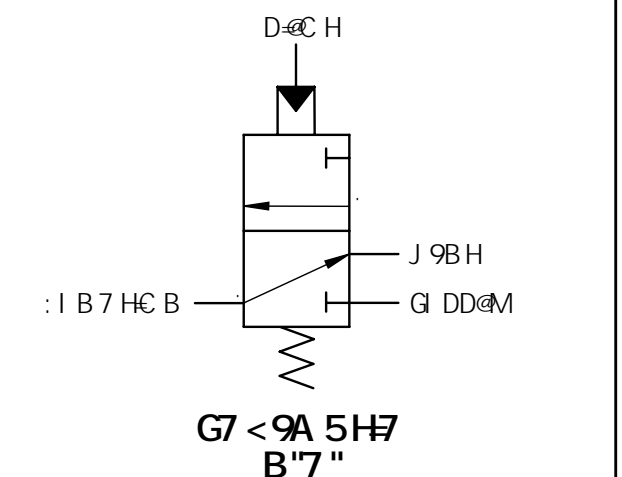
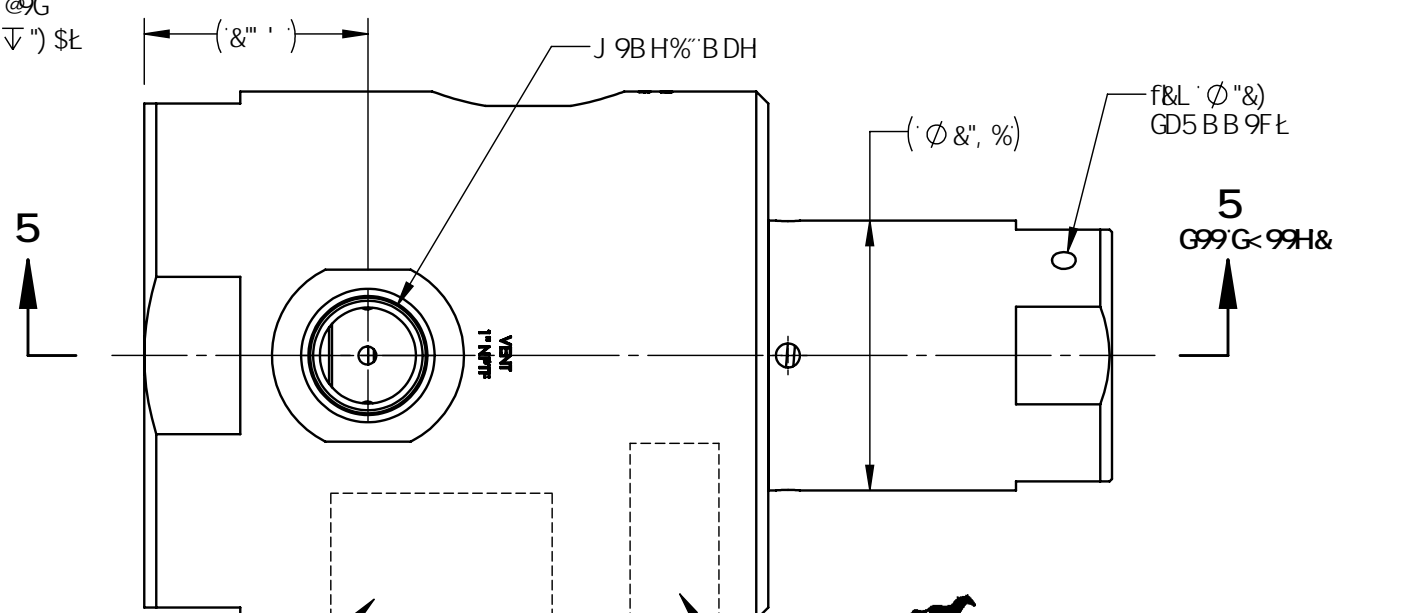
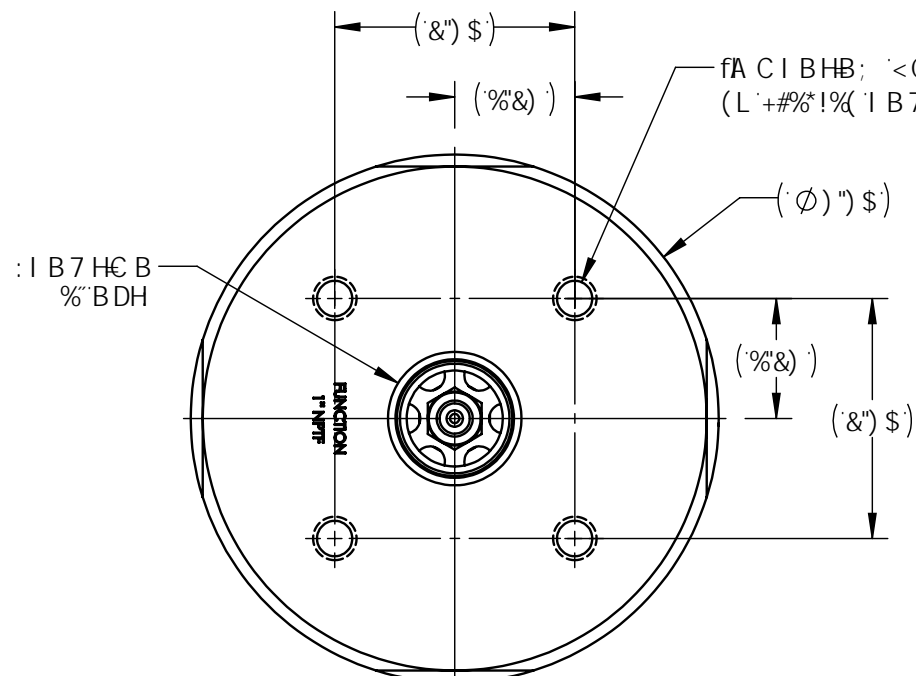

&- %\$-  
 J 9F'f5L'J 9FG@B' L  
 FG9F-5@BI A 69F!  
 G5A 9'G#B'5G75FH-F; 9L  
 D5H9BHD9B8-B;  
 ) \$\$\$ DG=  
 fB5H9'C: 'A: ; L  
 G99'G<C D'H F5J 9@F  
 : CF'588 #CB5@  
 -B: C'F9E I #98



A 5F?K #k: @; C'5B8  
7CA D5BM-B: CFA 5HC B

D5H9BHD9B8-B;

A 5H9F-5@ G99'D5FHG'CB-B8=J'6CA	8'A 9BGC BG5B8'HC @F5B7'9G5F9 B-B7<9GD9F 5GA 9Mk(')A 1%-('" I B@GGC H: 9FK @9 GD97 ≠ 98. %L HC @F5B7'9G "L: ±% "LL: ±\$% "LLL: ±\$\$) 5B; @G: ±)" &L G F: 57'9H9LH F9. "	5DDFC J 5@ 8F5K B 6M 7<97?98'6M 9B; B 99F 9FB BI A 69F	JOP CMJ AJP \$&', % \$%#&- #&\$	85H9 4/09/20 85H9 4-13-20 85H9 4/10/20 85H9	 9B; B99F-B; <b>J 5@ 9Z%'Z GDA Z; 9B &amp;Z B'7'Z</b> <b>%'BDH '6@7? DC FHG'Z %#('"</b> <b>BDH 'D@C HDC FH</b>	GAP 6	8K; BC	F9J 5
7CB8#CB.	'L 7CF58-5@: 95H F9G<5@69 K #k-B "\$%\$ (L 6F95? G<5FD 98; 9G"\$%\$ ) L-BH9F B5@F58=G<5@69"\$%\$'A 5L *L 8F @DC-BHG C DHC B5@K <9B G<C K B I BGD97 ≠ 98Z5@8F @DC-BH5B; @G G<5@69 69K 99B -S'1%\$	Hk9-B: CFA 5HC B 7CBH5-B98-B Hk-68F5K-B; 6Hk-9 GC @DFC D9FHMC: ; @A CF9J 5@97C I B@GGC Hk9FK @9 G5H98" 5BMF9DFC 8I 7HC B-B D5FHCF K <C @K #k C I H Hk9K F#H98 D9FA @GC B C: ; @A CF9J 5@97C @DFC <4#98"				G7 5@ % (	Gc JK cf_g	G<99H % C: &

(

&

%

6@C: A 5HF-5@					
#PA BC	D5FHBI A 69F	8 9G7 F-DHC B		A 5HF-5@	F? G?
%	&- %\$	J 5@ 9Z 7 5FF -8; 9Z GDA Z; 9B &z%Z B"C "C F B"7 "z) z\$\$\$ DG-GI DD@M%#("' BDH 'D-C HDC FH		F 9: 9F 'HC 'B 8J 'D5FHG	% L L
&	&+ ' -)!&	6@ 7 ? z J 5 @ 9Z GDA Z B "7 "z% "BDH z * \$\$\$ DG=		&+ ' -)	%

6

6

5

5

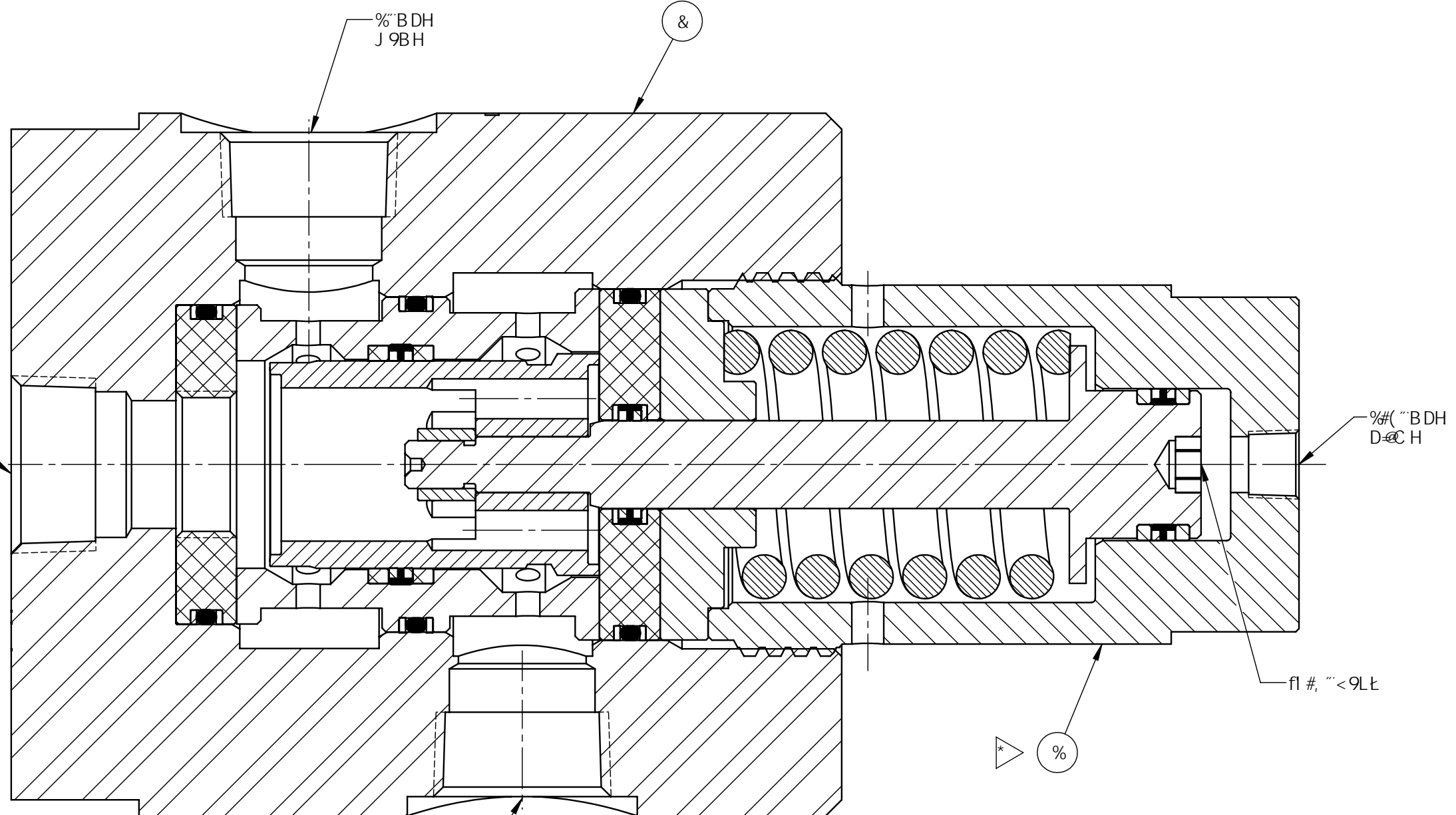

:1 B7 HC B  
%\"/>

%\"/>

&

%#('\"/>

fl #, \"/>

\* %

%\"/>

G97 HC B '5!5



9B; B99F-B;

GA9	8K; BC			F9J
<b>6</b>		<b>&amp;- %\$-</b>		<b>5</b>
G75@	%('	Gc'JK cf_g	G<99H & C: &	

(

&

%

BC H9G

A 5F? 7 CA DC B9BHK #k 5GG9A 6@MK "C "BI A 69F 5GG<CI @CB  
7 CA DC B9BH8F5K B;

A 5F? B; A 5F? 5GG<CK B I GB; @5G9F 9H7 <CF 7 CA DI H9F  
7 CBHC @98 8CHD99B A 5F? B; A 57 <B9Z "\$\* < < A B 7 <5F57 H9FG"

CF 6CHCA G95@F9A CJ 5@I G9HC C @5H@%\$%\$!\$\$&"

LZB 7C @ A B 89D=7 HG D5FHG B G95 @? H&- %\$G?"

LZB 7C @ A B 89D=7 HG D5FHG B F9D5 F ? H&- %\$F?"

HC FE I 9HC &) : H@6G"

HC FE I 9HC " \$\$: H@6G B 6@ 7? I GB; GD97 5@  
HC C @5H@%\$%\$%

5@A 5BI : 57 H F98 #9A G5F9D5GGJ 5H98"

5GG9A 6@MDFC 7 98I F9. .... ) \$& , &  
G5B85F8 : 5HDFC 7 98I F9. .... ) \$& ,  
9LH9B898 : 5HDFC 7 98I F9. .... ) \$& ,  
G9FJ 7 9A 5BI 5@ ..... ) %\$&\*

F9J GCBG				
F9J	9FB #97C BI A 69F	8F5K B	7 <97?98	5DDFC J 98
5	9FB '\$&' , %	JOP 4/13/20	CMCJ 4-13-20	AQP 4/13/20

DF9GGI F985H5  
 GI DD@MA 5K D. ) \$\$\$DG=  
 D@ HA 5K D. ) \$\$\$DG=  
 5H) \$\$\$DG=GI DD@MF97 CA A 9B898  
 A B A I A D@C HDF9GGI F9. " \$\$\$DG=  
 5H' \$\$\$DG=GI DD@MF97 CA A 9B898  
 A B A I A D@C HDF9GGI F9. & \$\$\$DG=  
 :@K 85H5  
 7j 1;  
 A 5L A I A :@K 75D57 #M "%+); DA  
 :@ 8G "%LK 5HF 65G98 8F @B;  
 ..... 7 CBHC @: @ 8"  
 ..... &"LA B 9F5@C @65G98 8F @B;  
 ..... 7 CBHC @: @ 8"  
 : 9B9F5@85H5  
 H9A D9F5H F9F5B; 9. " &: HC %\$ %;  
 5DDFC L K 9# <H ..... %\$ @G  
 : 9@ G9FJ 7 956@

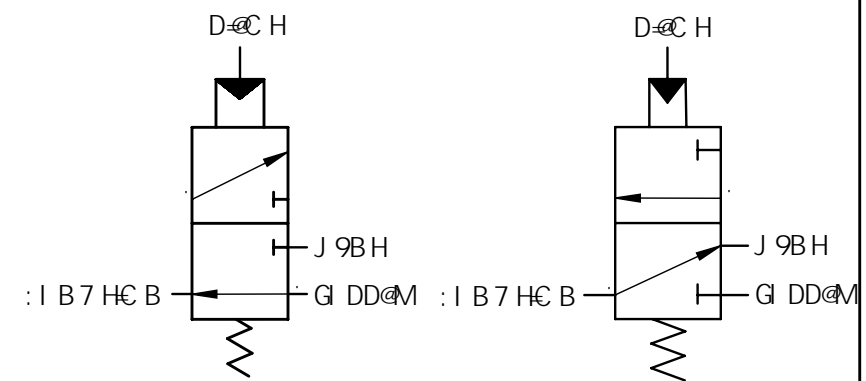
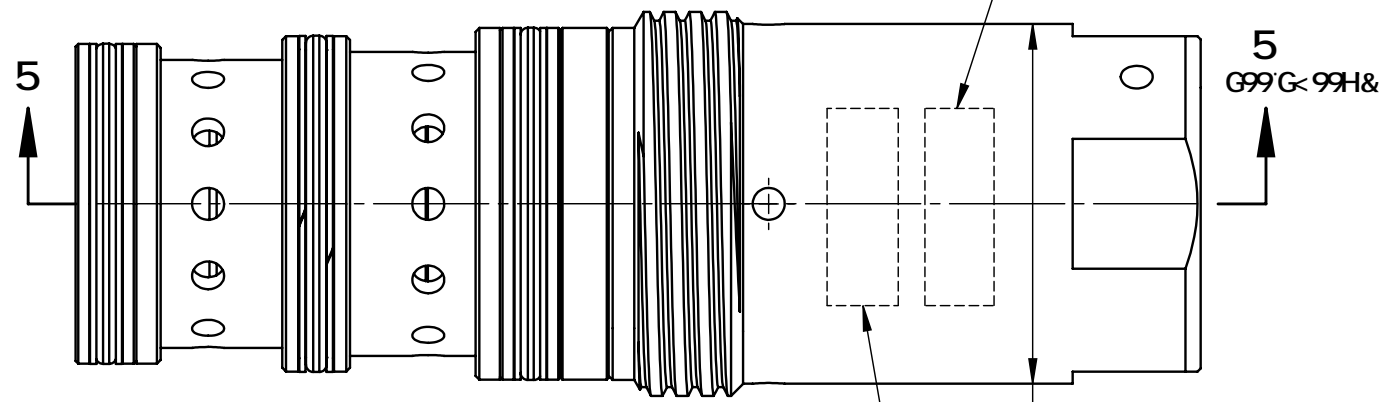
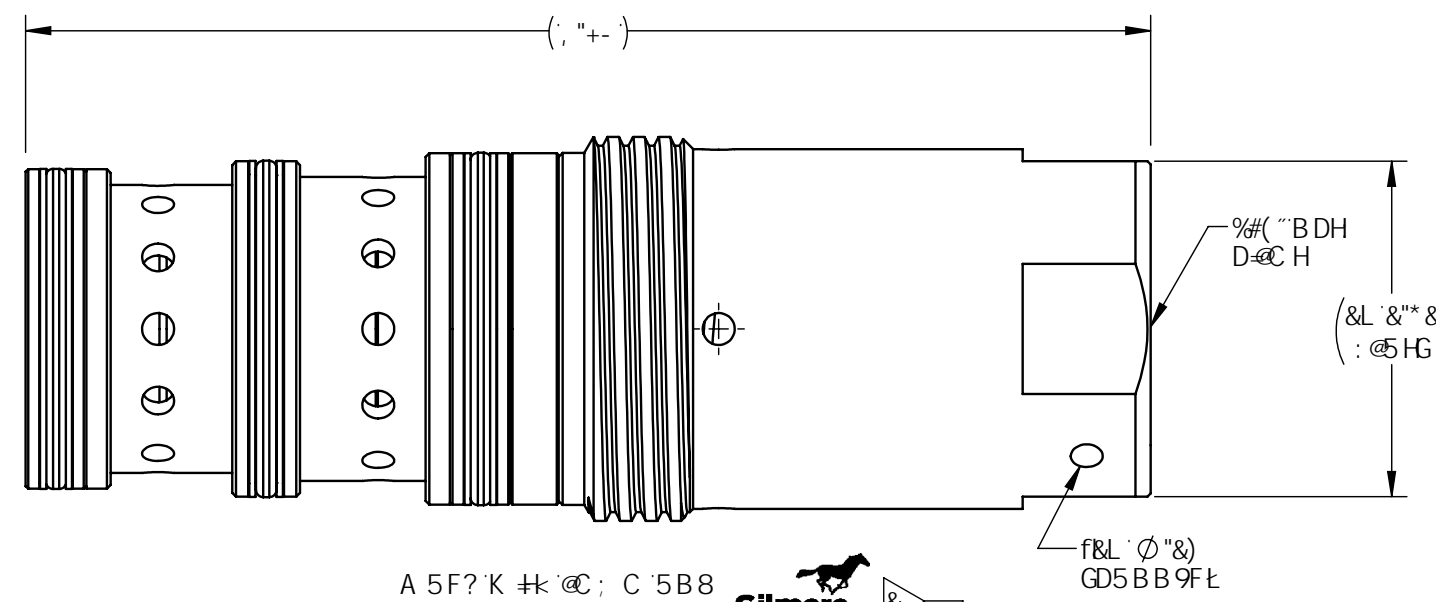

G7 <9A 5H7  
B"C"

G7 <9A 5H7  
B"7"

D5H9BHD9B8 B;

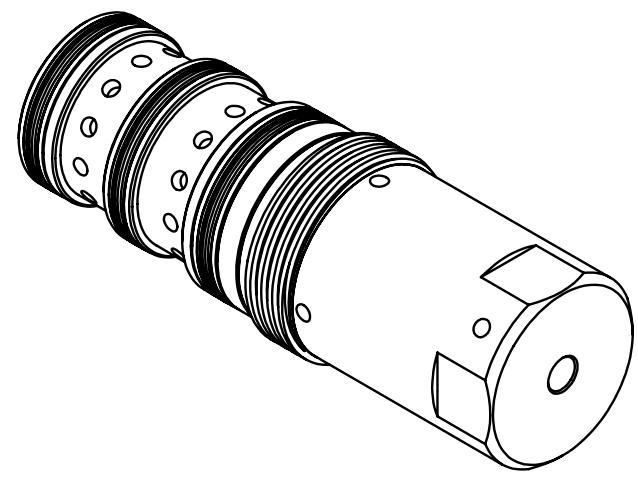
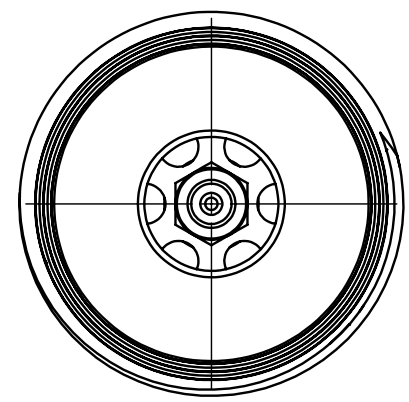

A 5H9F 5@ F9: 9F HC B8J D5FHG	8A 9BGC BG5B8 HC @F5B7 9G5F9 B B7 <9GD9F 5GA 9M( ) A 1% - (" I B @GGC H: 9FK @9 GD97 = 98. %L HC @9F5B7 9G "L: ±% "LL: ±\$% "LLL: ±\$\$) 5B: @9G ±") *	5DDFC J 5@	85H9 4/13/20	<p>9B; B99F B;</p> <p>J 5@ 9Z 7 5FH B; 9Z GDA Z; 9B &amp;Z %Z B"C "CF B"7 "Z) \$\$\$DG=GI DD@M %#( "BDH D@C HDC FH</p>
7CB8 #HC B.	%L HC @9F5B7 9G "L: ±% "LL: ±\$% "LLL: ±\$\$) 5B: @9G ±") *	8F5K B 6M JOP 4/13/20	85H9 4-13-20	
HF95HA 9BH	&L G F: 57 9H9LH F9. ** ✓ "L 7CF58 5@: 95H F9GG<5 @69 © K #k B "\$%\$ (L 6F95? G<5FD 98; 9G "\$%\$ ) L B H9FB5 @F58 =G<5 @69 "\$%\$ A 5L *L 8F @DC B HG C DHC B5 @K <9B G<C K B I BGD97 = 98 Z5 @8F @DC B H5B; @9G G<5 @69 69K 99B - \$ "%\$ *	7 <97?98 6M CMCJ 4-13-20	85H9 4/13/20	
DFC 7 98I F9 BI A 69F.		9B: B 99F AQP 4/13/20	85H9 4/13/20	
		9FB BI A 69F \$&' , %	85H9 \$%#& , #&\$	<p>GAP 8K: BC</p> <p>6</p> <p>G7 5@ % ( Gc JK cf_g G&lt;99H % C: &amp;</p>

6

6

5

5



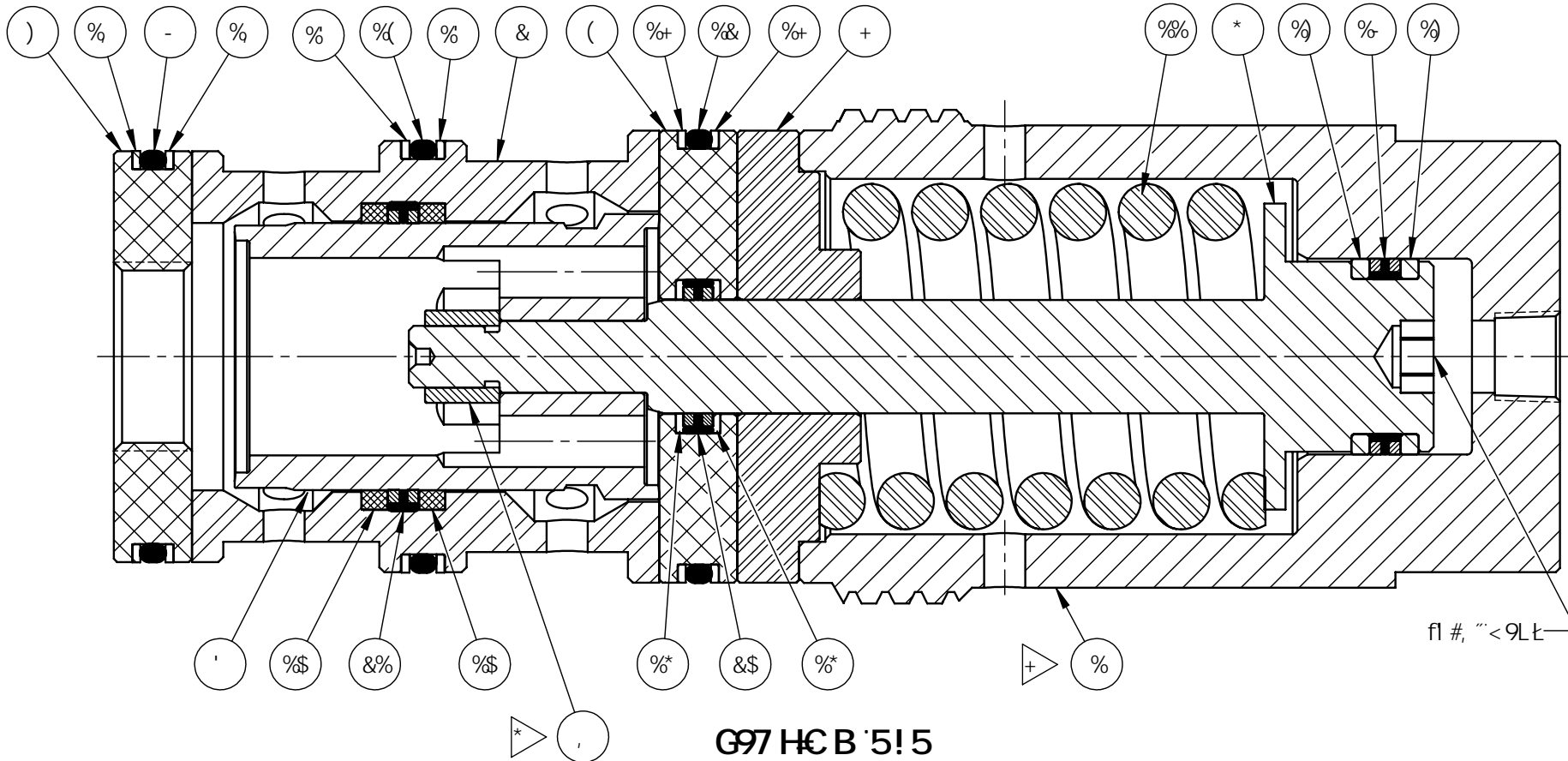

6-@C: A 5HF-5@

#PA BC	D5FH BI A 69F	8 9G7 F-@HC B	A 5HF-5@	E HM	F?	G?
%	% ' * \$(	GDF-B; < C I GB;	5 &+ ' HD G& % \$\$ FB #FC B-7 * \$L	%		
&	% ' ) -,	GD5 7 9F Z J 5 @ 9Z GDA Z % Z ; 9B &	5 &+ ' HD G& % \$\$ FB #FC B-7 * \$L	%		
'	% ' ) - -	G95 @G@9J 9	5 &+ ' HD G& % \$\$ FB #FC B-7 * \$L	%	L	
(	% ' * \$\$	G95 HZ HC D Z J 5 @ 9Z GDA Z % Z ; 9B &	8 9@F B ) % @D	%	L	L
)	% ' * \$%	G95 HZ 6C HC A	8 9@F B ) % @D	%	L	L
*	% ' * \$&	D-@HC B FC 8 Z G< C I @ 9F 98	5 &+ ' G& \$- % \$ FB #FC B-7 ) \$L	%		
+	% ' * \$'	6I G< B; Z J 5 @ 9Z GDA Z % Z ; 9B &	5 GHA ' 6% ' - 7 * % ( \$ \$ FB @ A -B I A ' 6FC BN 9L	%		
,	& % % & ! % \$ \$)	< 9L @ C 7 ? ' B I HZ BM @ C B	: ) - ( ' 5 @ @ C M; F ' & z BM @ C B fl % * G L	%	L	L
-	% % \$ ! % \$ % 2 %	C I F B;	< B 6F	%	L	L
% \$	& + % %	K 95 F ' 65 B 8	8 9@F B ' 5;	&	L	L
% %	& + % +	GDF-B; ' 7 C A DF 9G @ C B	' 5 ' % ' HD ' %'	%		
% &	% % \$ ! % % ( ? %	C I F B;	< B 6F	%	L	L
%	& \$ - & + %	F-B; Z 65 7 ? I D	D 99?	&	L	L
% (	% % \$ ! % % 2 %	C I F B;	< B 6F	%	L	L
% )	% ' * \$)	K 95 F ' 65 B 8	8 9@F B ' 5;	&	L	L
% *	% ' * \$*	F-B; Z 65 7 ? I D	D 99?	&	L	L
% +	% ' * \$+	F-B; Z 65 7 ? I D	D 99?	&	L	L
%	% ' * \$,	F-B; Z 65 7 ? I D	D 99?	&	L	L
%	% % \$ ! % \$(	HG95 @D-@HC B	7 5 F 6 C LM @ H 8 B #F @ # BM @ HFC B	%	L	L
& \$	% % \$ ! % ) \$-	HG95 @FC 8	7 5 F 6 C LM @ H 8 B #F @ # BM @ HFC B	%	L	L
& %	& \$ + ) ,	HG95 @G@9J 9	7 5 F 6 C LM @ H 8 B #F @ # BM @ HFC B	%	L	L

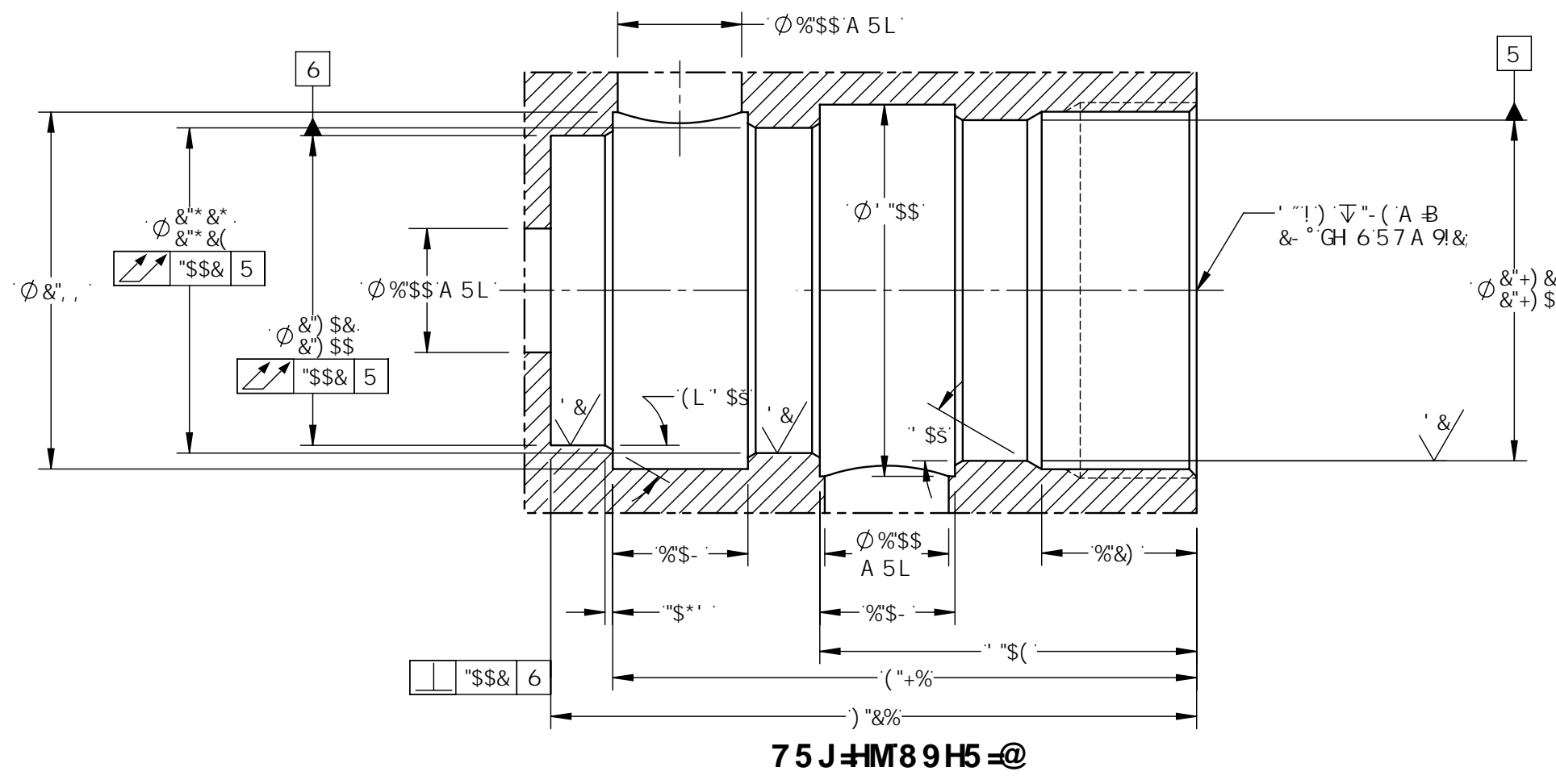

**Gilmore** a precision company

8B; B99B;

GAD	8K; BC	F9J
<b>6</b>		<b>5</b>
G75@	% (	Gc JK cf_g
		G-99H & C: &

BC H9G  
 A 5F?B: A 5F?7CA DCB9BHK #k 5GG9A 6@MK "C"  
 5GG<CK B'CB'H<97CA DCB9BH8F5K -B;  
 A 5F?B: A 5F?5GG<CK B'I GB; @G9F 9H7 <CF 7CA DI H9F  
 7CBHC @98 8CHD99B A 5F?B; A 57 <B 9Z"\$\* <≠ <  
 A B'7 <5F57 H9FG"  
 : CF'6CHCA G95@F9A CJ 5@I G9HC C @5H@%\$\$\$!\$\$\$&  
 (" LZ-B 7C @ A B'89D=7HG'D5FHG-B G95@?H&- %0\$G?"  
 )" LZ-B 7C @ A B'89D=7HG'D5FHG-B F9D5 F ?H&- %0\$F?"  
 \* HC FE I 975FH F-B; 9HC " \$\$: H@G'B A 5B=C @6@7?  
 I GB; GD97 5@HC C @5H@%\$%00"  
 + 5GG9A 6@MDFC 798I F9.....) \$& &  
 G5B85F8: 5HDFC 798I F9.....) \$& &  
 9LH9B898: 5HDFC 798I F9.....) \$& &  
 G9FJ 79A 5BI 5@.....) %\$&\*

F9J GCBG				
F9J	9FB #97C BI A 69F	8F5K B	7 <97?98	5DDFC J 98
5	9FB '\$&, %	JOP 4/13/20	CMJ 4-13-20	AQP 4/13/20

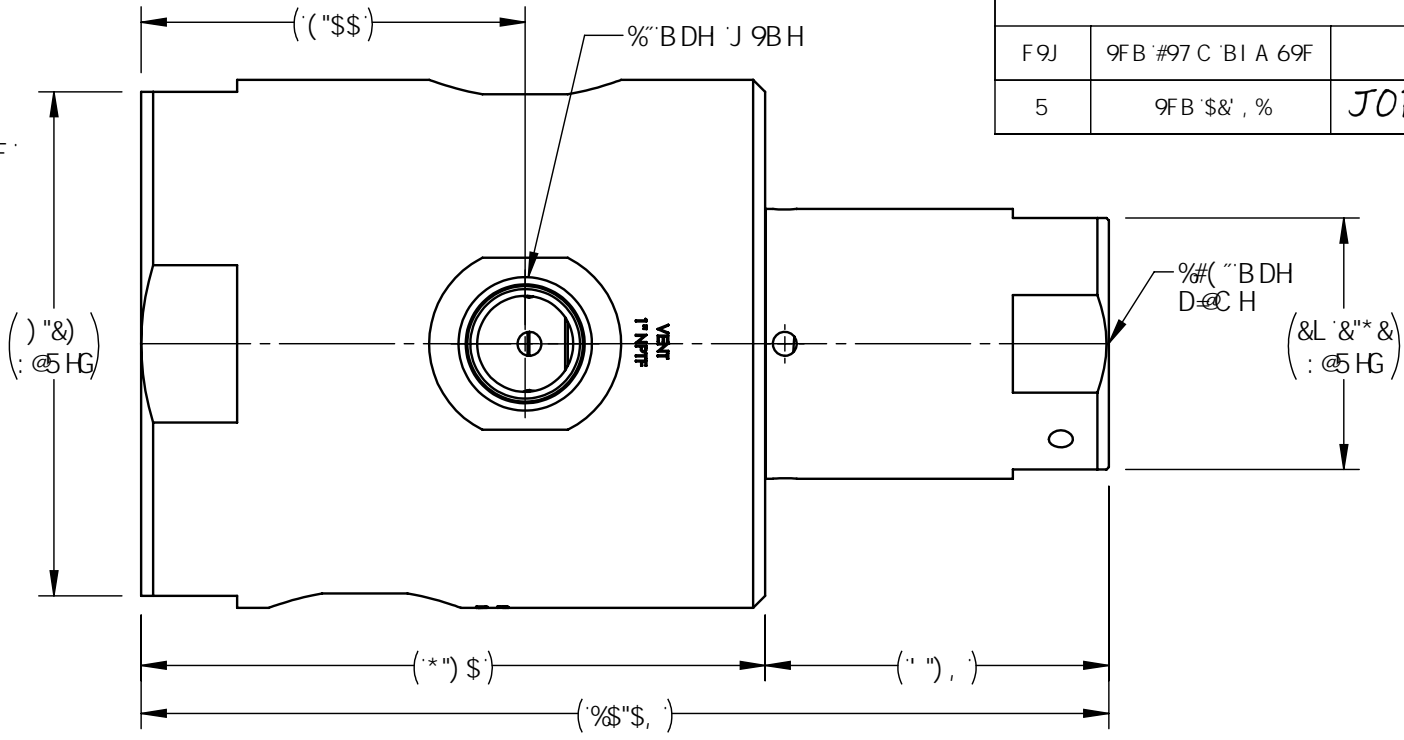

DF9GG F985H5  
 GI DD@MA 5K D: ) \$\$\$ DG=  
 D@ HA 5K D: ) \$\$\$ DG=  
 5H) \$\$\$ DG=GI DD@MF97CA A 9B898  
 A B A I A D@HDF9GG F9: ) \$\$\$ DG=  
 5H) \$\$\$ DG=GI DD@MF97CA A 9B898  
 A B A I A D@HDF9GG F9: ) \$\$\$ DG=  
 :@CK 85H5  
 7j 1;  
 A 5L: @CK 75D57 #M%+); DA  
 :@BG %LK 5HF 65G98 8F @B;  
 7CBHC @: @-8"  
 &LA B9F5@C @65G98 8F @B;  
 7CBHC @: @-8"  
 DC FHG  
 GI DD@M " " %"BDH  
 : I B7HC B " " %"BDH  
 J 9BH " " %"BDH  
 D@C H " " %#("BDH  
 : 9B9F5@85H5  
 H9A D9F5H F9F5B; 9: " &: HC %0\$":  
 5DDFC L'K 9< <H'(' @6G  
 : 9@8 G9FJ 7956@

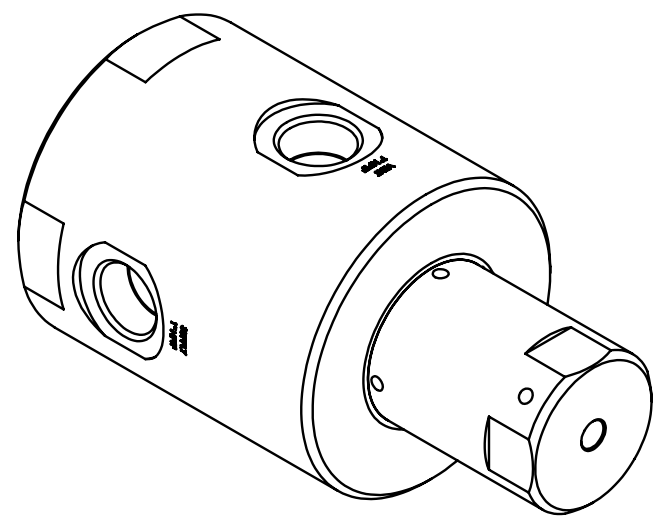
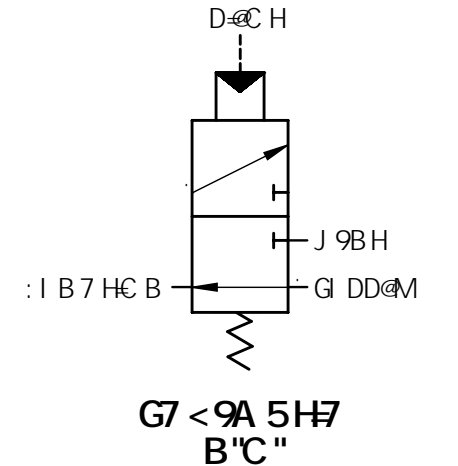
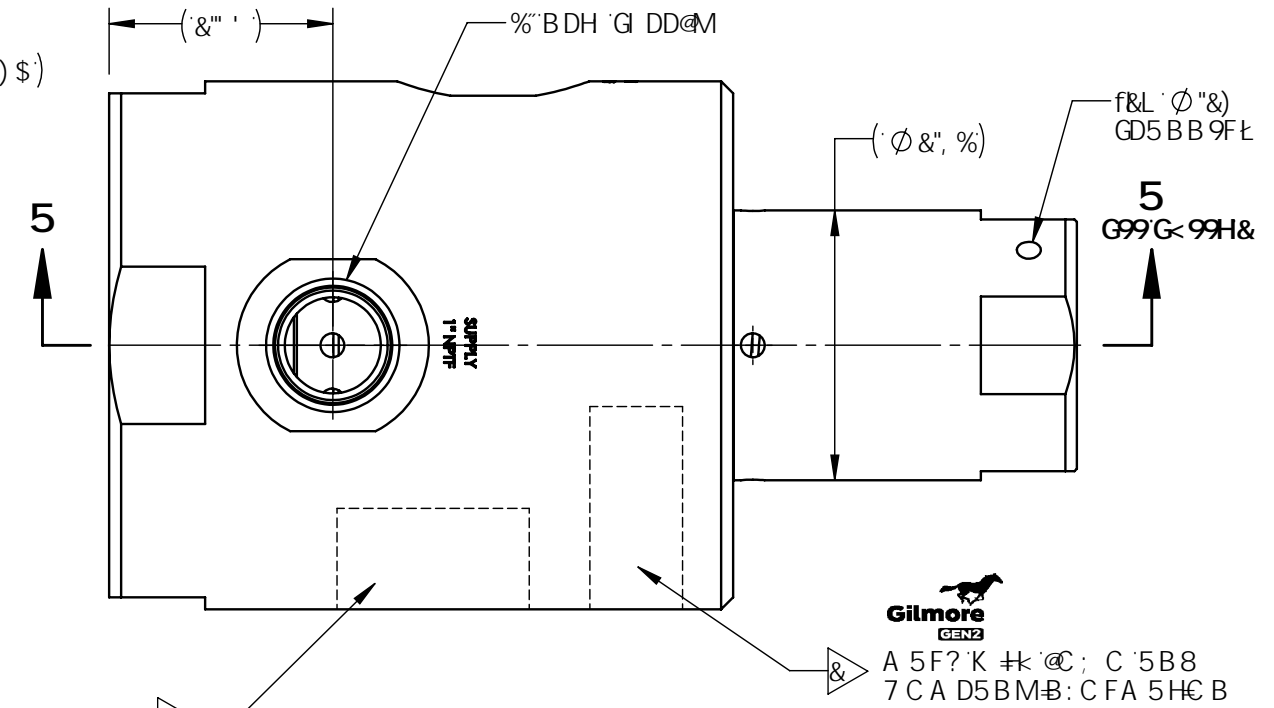
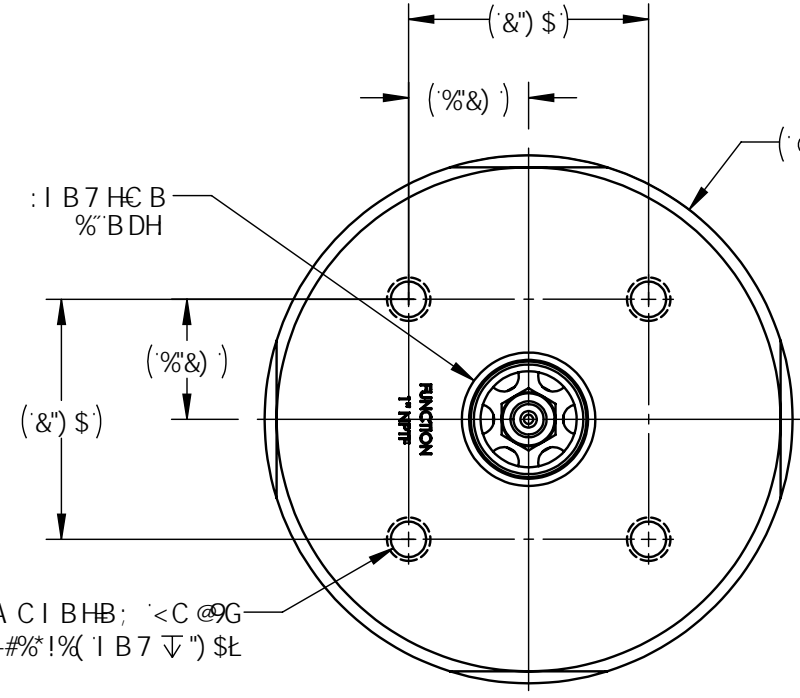

&- %00%  
 J 9F f5L J 9FGC B: L  
 fG9F 5@BI A 69F!  
 G5A 9'G#B 5G 75FH F-B; 9L  
 D5H9B HD9B 8-B;  
 ) \$\$\$ DG=  
 fB5H9C: A: ; L  
 G99'G<C D'HF 5J 9@9F  
 : CF 588 #C B5@  
 -B: C F9E I F 98

A 5H9F 5@ G99 D5FHG C B -B 8 = 6CA		8A 9BGC BG5B8 HC @F5B7 9G5F9 B -B 7 <9GD9F 5GA 9M(") A 1% - (" I B @GGC H: 9FK @9 GD97 = 98. %L HC @F5B7 9G "L: ±% "LL: ±\$% "LLL: ±\$\$) 5B: @G ±") &L G F: 57 9H L H F9. "✓		5DDFC J 5@	
7CB8 #CB.	7CB8 #CB.	8F5K B 6M	JOP	85H9	4/13/20
HF95HA 9BH	HF95HA 9BH	7 <97?98 6M	CMJ	85H9	4-13-20
DFC 798I F9BI A 69F.	DFC 798I F9BI A 69F.	9B: B 99F	AQP	85H9	4/13/20
		9FB BI A 69F	\$&, %	85H9	\$%#&- #&\$
		H: 9-B: CFA 5HC B 7CBH5-B98-B H: 68F5K-B: 6H: 9 GC @DFC D9FHC: : A CF9J 5@ 97C I B @GGC H: 9FK @9 G5H98" 5B MF9DFC 8I 7HC B -B D5FHC F K <C @K #C I H H: 9K F #H9 D9A GGC B C: : A CF9J 5@ 97C GDFC <4H98"			

**Gilmore** 9B; B99F-B;  
 a pro/ery company

**J 5@ 9Z%žGDA ž; 9B &žB'C'ž**  
 %"BDH 6@7? DC FHG %#("'  
 BDH D@C HDC FH

GAP	8K: BC	F9J
<b>6</b>	&- %00%	<b>5</b>
G7 5@ % (	Gc JK cf_g	G<99H % C: &

6

6

5

5

(

&

%

6@C: 'A 5H9F-5@					
#9A 'BC	D5FHBI A 69F	8 9G7 F-DHC B	A 5H9F-5@	E HM	F? G?
%	&- %8\$	J 5@ 9z7 5FH B; 9zGDA z: 9B '&z%' B"C "C F B"7 "z) z\$\$\$DG=G DD@z%#("' BDH 'D@C HDC FH	F 9. 9F 'HC 'B 8J 'D5 FHG	%	L L
&	&+ ' -)!%	6@C 7?zJ 5@ 9zGDA zB"C "z%"BDH z *\$\$\$DG=	5&+* 'HD' %'	%	

6

6

5

5

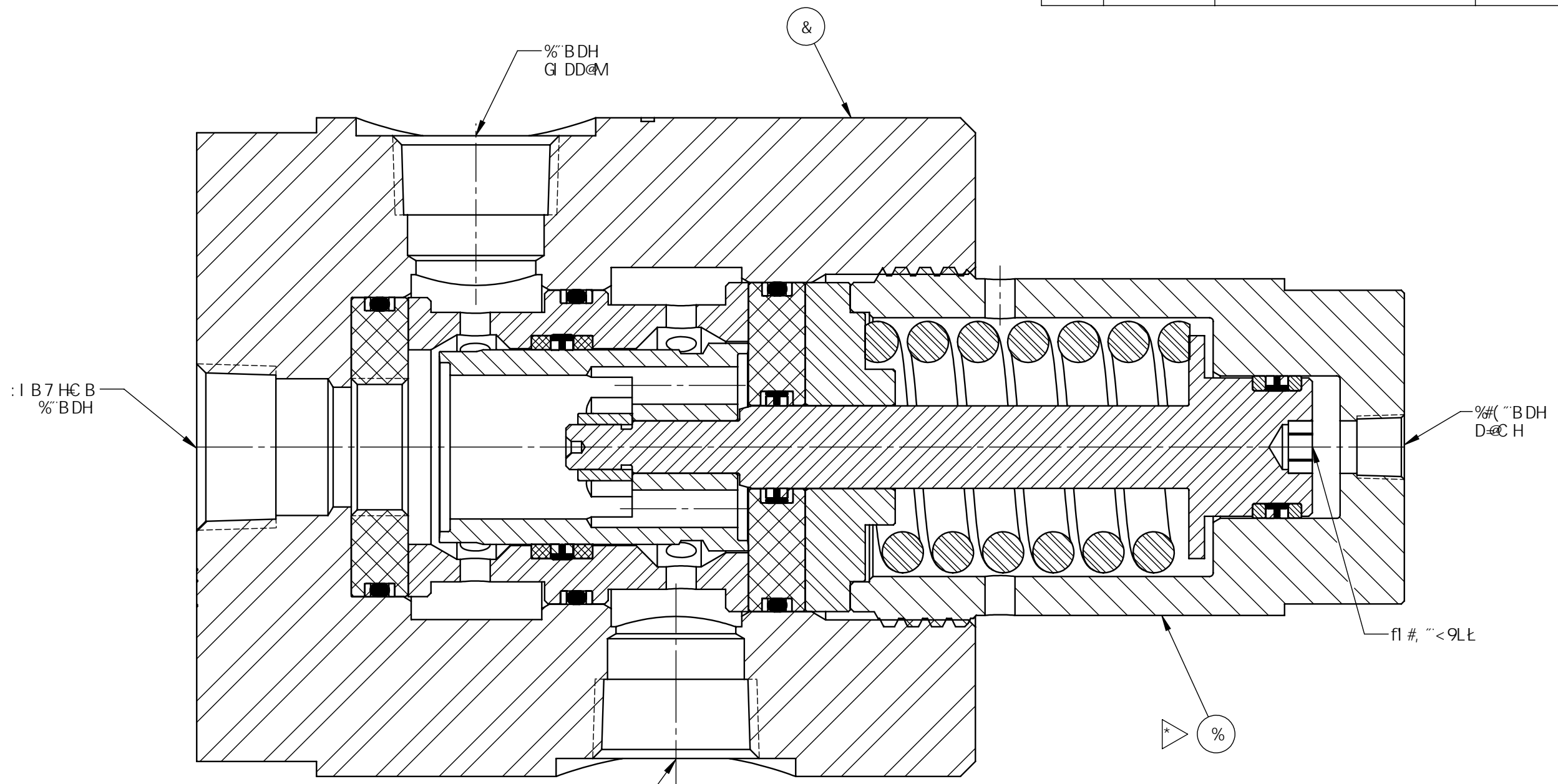

: I B 7 HC B  
%BDH

%BDH  
G DD@M

&

%# 'BDH  
D@C H

fl #, "'<9Lk

\* %

%BDH 'J 9BH  
fG<CK B 'FC H5H98 ' - \$°C I HC : 'DC G#HC B  
: CF @ GF5HC B 'DI FDC G9G

G97 HC B '5!5



9B; B99F-B;

GAD	8K; 'BC	F9J
<b>6</b>	&- %8%	<b>5</b>
G75@	%('	Gc 'JK cf_g
		G<99H & C: &

(

&

%





BC H9G

A 5F?B; A 5F?7CA DCB9BHK #k 5GG9A 6@MK "C"  
5GG<CK B'CB'Hk97CA DCB9BH8F5K B;  
A 5F?B; A 5F?5GG<CK B'IGB; @5G9F 9H7 <CF  
7CA DI H9F 7CBHFC @98 8CHD99B A 5F?B; A 57 <B9z  
"\$\* <÷ <A B 7 <5F57H9F"

H9GHDFC 798I F9.....) \$\$, +  
5GG9A 6@MDFC 798I F9.) \$\$, &  
G9FJ 79A 5BI 5@.....) %\$&\*

HC FE I 9'GDA BHC 6@7?K #k 5H@%\$%0%5H' \$\$: H@6"

A I GH69'GH5A D98 DF-€ F HC 5GG9A 6@M

I G9'G 6'5GG9A 6@MF9D5 F ? #I

I G9'G 6'5GG9A 6@MG95 @? #I

+ " : C F 6C HC A G95 @F9A C J 5 @I G9'HC C @5H@%\$%\$!\$\$&"

, " LZB 7C @ A B 89D=7 HG D5FHG B G95 @? #I &- %\$G "

- " LZB 7C @ A B 89D=7 HG D5FHG B F9D5 F ? #I &- %\$F ?"

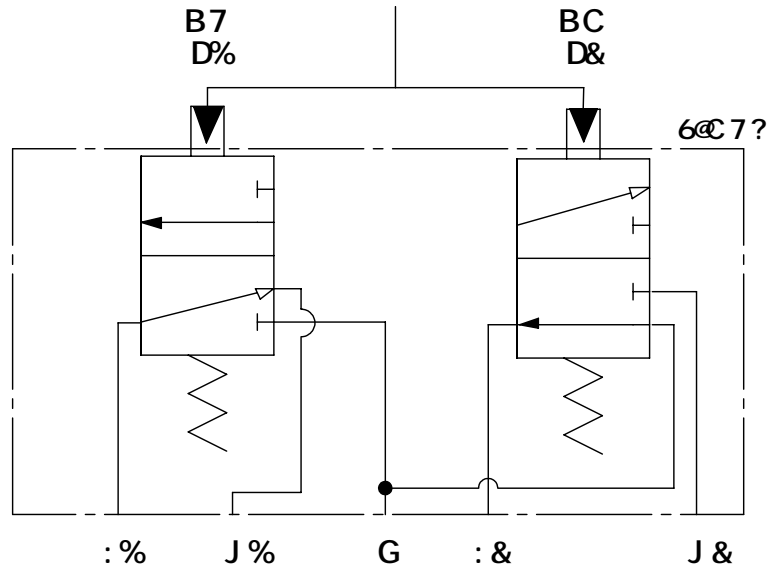

G7 < 9A 5H7

F9J GCBG				
F9J	9FB #97C BI A 69F	8F5K B	7 <97?98	5DDFC J 98
5	9FB '\$&', %	JOP 4/20/20	CMJ 4-20-20	AQP 4/20/20

DF9GG F985H5

GI DD@MA 5K D. ) \$\$\$DG=  
D-@ HA 5K D. ) \$\$\$DG=

5H) \$\$\$DG=GI DD@MF97CA A 9B898  
A-B A I A D-@ HDF9GG F9. ) \$\$\$DG=

5H' \$\$\$DG=GI DD@MF97CA A 9B898  
A-B A I A D-@ HDF9GG F9. ) \$\$\$DG=

:@K 85H5

7j 1;  
A 5L : @K 75D57 #M%+) ; DA

: @ 8G %LK 5HF 65G98 8F @@B;

.....7CBHFC @; @ 8"

.....&L'A B9F5@C @65G98 8F @@B;  
.....7CBHFC @; @ 8"

DC.FHG

GI DD@M... %BDH  
: I B7HC B %'' %BDH  
: I B7HC B &'' %BDH  
J 9BH %BDH  
D-@ H %H("BDH  
D@ ; %G59

: 9B9F5@85H5

H9A D9F5H F9F5B; 9.1' &°: HC %\$°:

5DDFC L'K 9z <H''% @6G  
: 9@8 G9FJ 7956@

6

6

5

5

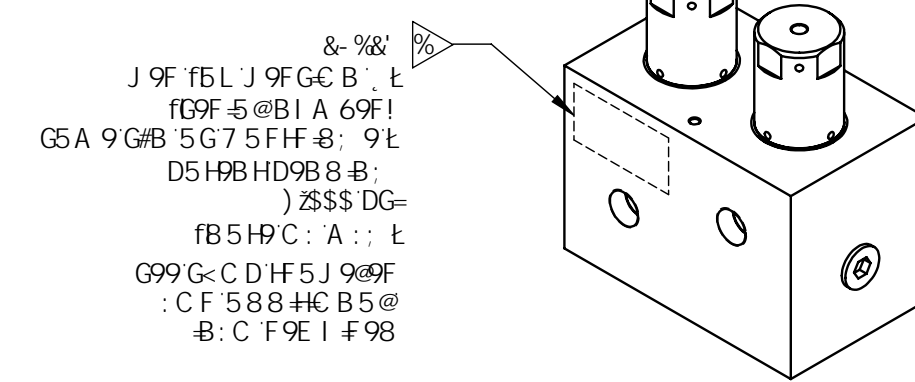
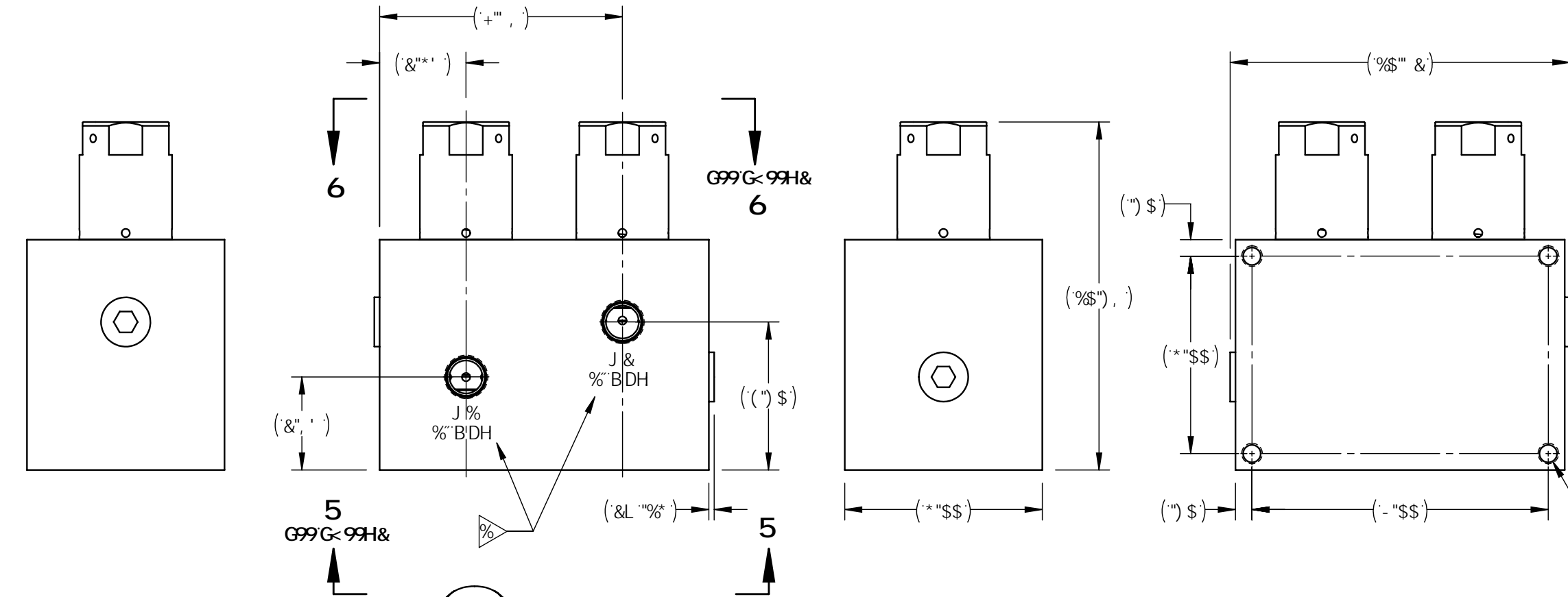

A 5HF 5@ F9: 9F HC B8 = 6C A #9A G	8A 9BGC BG5B8 HC @F5B7 9G5F9 B B7 <9GD9F 5GA 9M(A) A1% - (" I B @GGC H: 9FK @9GD97 = 98. %L HC @F5B7 9G "L: ±% "LL: ±\$% "LLL: ±\$\$) 5B; @9G ±") *	5DDFC J 5@ 8F5K B 6M 7 <97?98 6M 9B; B99F 9FB BI A 69F	85H9 4/20/20 85H9 4-20-20 85H9 4/20/20 85H9	 9B; B99F-B; GDA ŽA J 5Ž; 9B &ž (!K 5M %ž%# ("' BDH D-@ H %'BDH 6@7? DC.FHG GAP 8K; BC 6 G7 5@ % ( Gc JXK cf_g F9J 5 G<99H % C: "
--	---	--	---	--

(

)

6

6

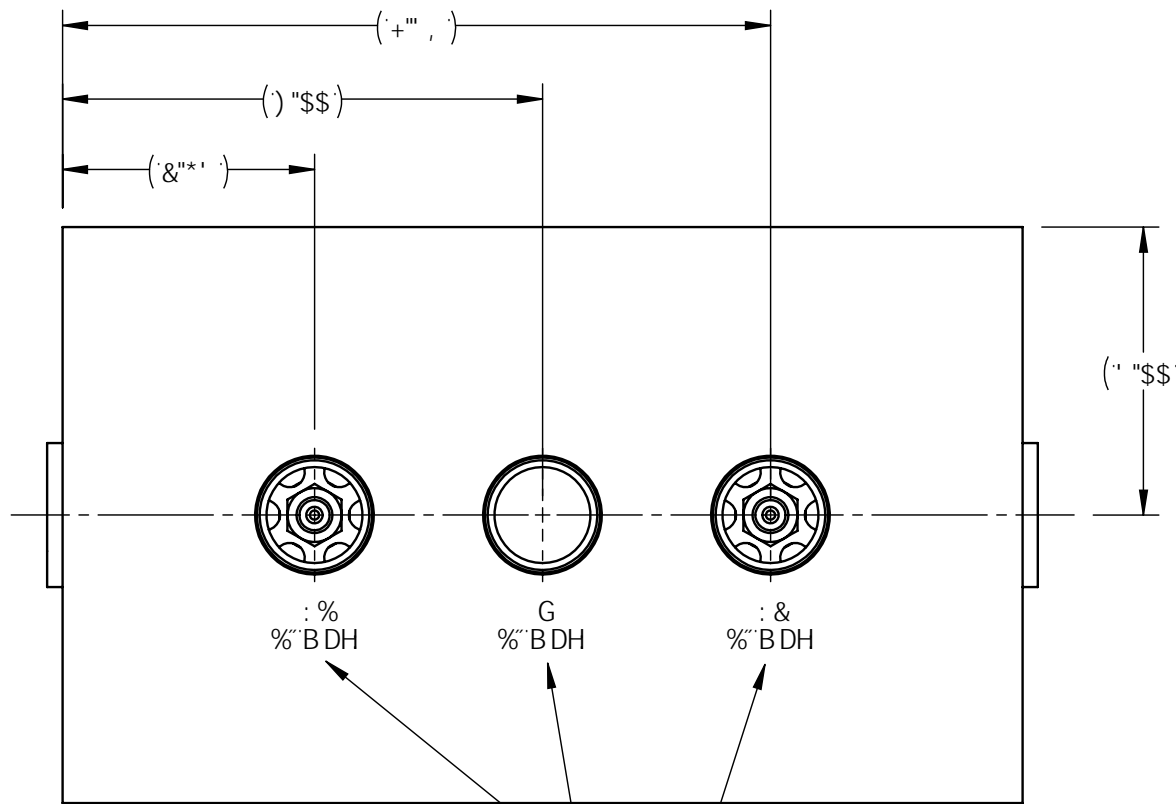

J-9K 515

7  
G99G<99H'

7

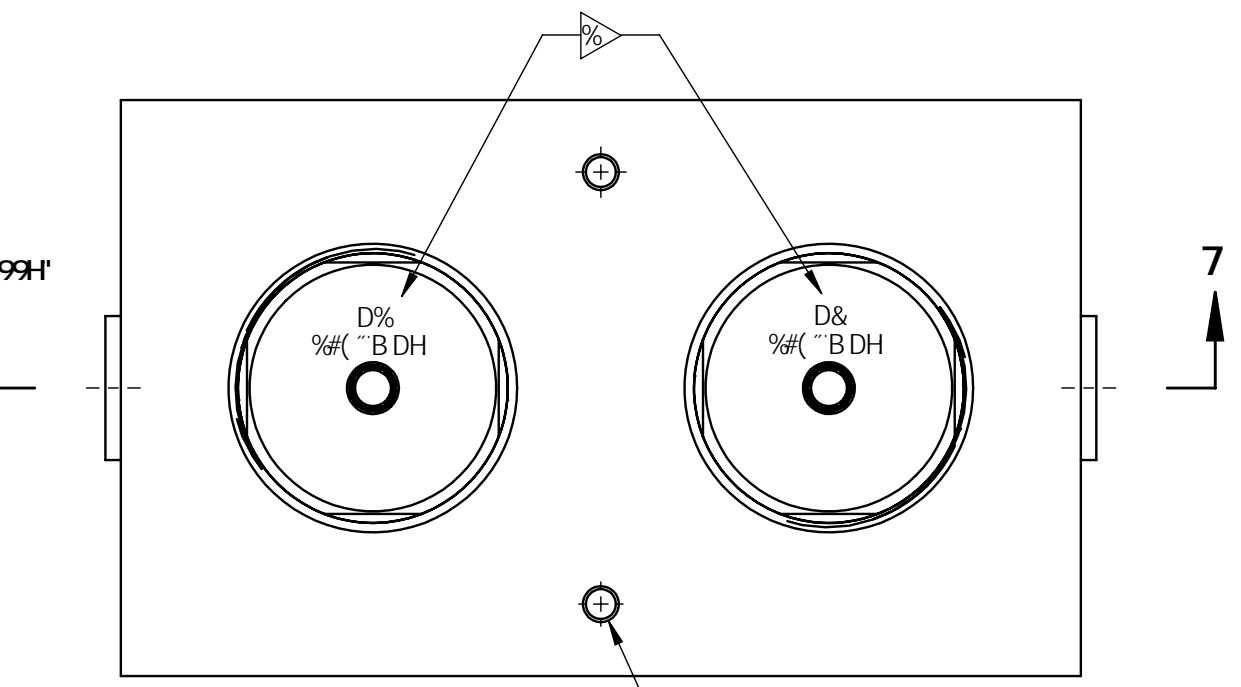

f&L '#, !% ' 1 B 7 ' L %' #' ( " @ : C F ' @ HB ; ' 9 M P G L

J-9K 616

5

5



9B; B99F B;

GAD	8K ; BC	F9J
<b>6</b>	&-%&'	<b>5</b>
G75@	%&	Gc'JK cf_g
		G<99H & C: '

(

)

&

%

(

&

%

6-@C: A 5H9F-5@

#9A BC	D5FHBI A 69F	8 9G7 F-@HC B	A 5H9F-5@	8YZJi h #E HM	F?	G?
%	%, \$*&	6@C 7?Z(IK 5M8I 5@%GDA	5&+* HD" %* 'f1 %' GGL	%	.	.
&	&- %&\$	J 5@ 9Z7 5FH-8; 9ZGDA Z; 9B '&Z%Z B"C "C F B"7 "z) Z\$\$\$ DG=GI DD@N%#("' BDH D@C HDC FH	F9. 9F 'HC 'B8J 'D5FHG	&	▷	*▷
'	% * \$' ! \$%*	D@ ; Z<9LZ<C @C K Z%'G59	'5&(\$ HD" %'	&	▷	*▷

6

6

5

5

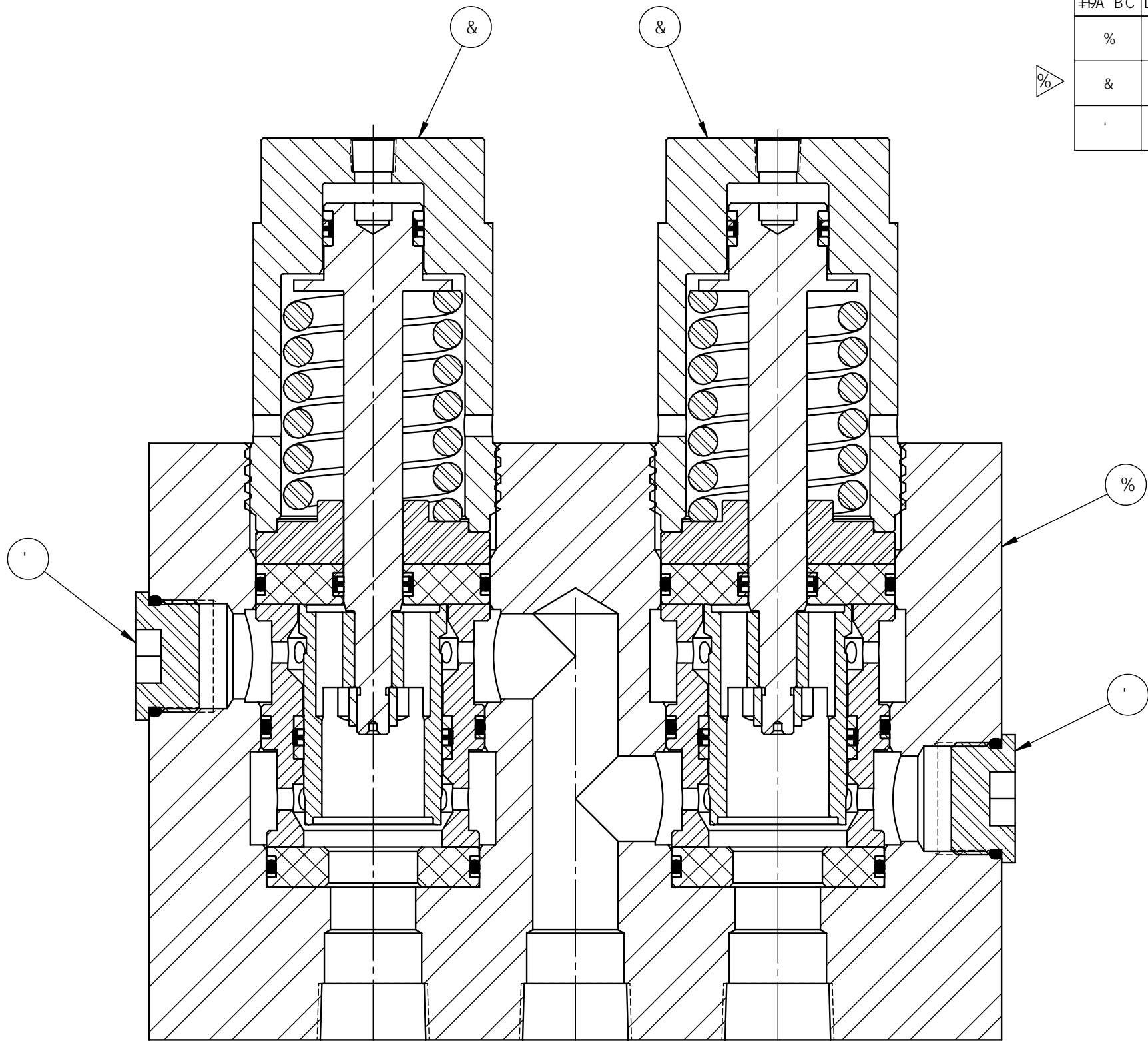

G97HC B 7!7



9B; B99F-B;

G49	8K ; BC		F9J
<b>6</b>		&- %&'	<b>5</b>
G75@	&.'	Gc'JK cf_g	G<99H ' C: '

(

&

%